



# DEWITT HIGH SCHOOL

*2022 Europe Concert Tour*

**15-day tour visiting**

***Holland, Belgium, France,  
Switzerland, Austria and Germany***

**Tentative Dates:**

**Thursday, June 30, 2022 to Thursday, July 14, 2022**

## **Tour & Air Inclusive Price:**

Adult Bus - \$4989

Student Bus - \$4689

To reserve your space, complete the Reservation Application and provide **\$100** per person by May 12, 2021.

An additional **\$499** per person deposit (includes \$249 Travel Protection Plan) will be due by October 20, 2021.

If all payments after the \$499 deposit are by check or ACH (not by credit card), before each deadline, you may subtract a \$100 discount off your final payment.

Operated by **IMAGE TOURS INC**

For questions, contact:

Monique Kasmauskis  
Phone: 1-800-968-9161 ext. 2290  
Email: dhs@imagetours.com

IMAGE TOURS, INC. (DHS)  
2828 Kraft Avenue SE, Suite A  
Grand Rapids, MI 49512

Revised: February 15, 2021

# DEWITT HIGH SCHOOL

## 2022 Europe Concert Tour

15-day (13-night) tour visiting Holland, Belgium, France, Switzerland, Austria and Germany

Thursday, June 30, 2022 to Thursday, July 14, 2022



## Included Features

**ROUND TRIP AIR TRANSPORTATION** from Chicago or Detroit on regularly scheduled airlines. Air and Land inclusive price includes a bus transfer from DHS to the airport. Those on the Adult Bus may have a different air schedule than the students and may fly from Lansing. Air schedules will be available approximately five months prior to departure.

**Note:** All students are expected to travel on the group flights. Requests to book air separately will be subject to approval and, if approved, the Tour Only pricing will be:

Adult Bus - \$3789 / Student Bus - \$3489

**LAND TRANSPORTATION** in Europe in accordance with the itinerary, including transfers and sightseeing from the time of arrival on Day 2 to the time of departure on Day 15, by deluxe air-conditioned motor coach.

**MEALS:** All breakfasts and all but one dinner while in Europe are included. Additional meals may be provided during the flights. One dinner in Delft and all lunches are at your own expense.

# DEWITT HIGH SCHOOL

## 2022 Europe Concert Tour

### Included Features (continued)

**ACCOMMODATIONS** for students will be provided in tourist-class hotels and student dormitories on the basis of up to eight students sharing a room. Members of the Adult Bus will be accommodated in superior-tourist and/or first-class hotels with the price based on two persons sharing a room. The participants on the Adult Bus will usually overnight in different hotels, often located in different nearby towns, than the participants on the Student Buses.

**TRAVEL PROTECTION PLAN** is included and is a non-refundable amount of \$249 per person. A full description of this Travel Protection Plan coverage is outlined in the "Travel Protection Plan Certificate of Coverage," which you can view at the following web links:

Student Travel Protection Plan: [www.tripmate.com/wpF430S/home](http://www.tripmate.com/wpF430S/home)

Adult Bus Travel Protection Plan: [www.tripmate.com/wpF432i/home](http://www.tripmate.com/wpF432i/home)

**DOCUMENTS:** By December 2021, the group website at [dhs.imagetours.com](http://dhs.imagetours.com) will offer additional travel preparation tips, information on "Obtaining a Passport," and a tentative Flight Schedule. About 2 weeks prior to departure, you will receive the final Trip Documents.

**SIGHTSEEING & ADMISSION** will be provided in accordance with the itinerar. The following highlights are included in the price:

- Amsterdam Boat Ride
- Paris Boat Ride
- Cable Car into the Swiss Mountains
- Mountain Toboggan Run near Innsbruck
- Neuschwanstein Castle
- Tyrolean Folklore Show in Innsbruck
- Salt Mines & Eagle's Nest in Berchtesgaden
- Dachau Visitors Center with Audio Guides
- Rhine River Boat Ride



**RESPONSIBILITY/LIABILITY** disclaimers as provided to Image Tours, Inc. by the Tour Contract are hereby extended to Mr. Mike Norman, the Band Boosters, the chaperones, DeWitt High School, and The DeWitt Board of Education.



# 15-day DeWitt Europe Concert Tour Itinerary

Please note the following information describes the Student Bus Itinerary. Although the Adult Bus Itinerary will be similar, hotel locations may differ. An itinerary, specific to the Adult Bus, will be sent with the Adult Bus Trip Documents Packet.

Transportation will always be provided for those on the Adult Bus who wish to attend the concert performances.

## DAY-BY-DAY ITINERARY

**Day 1 – THURSDAY, JUNE 30 – USA/ EUROPE...OVERNIGHT FLIGHT TO EUROPE.** Meet at the DeWitt High School to board the buses for the transfer to your U.S departure airport. Check-in and go through security prior to your flight departure.

**Day 2 – FRIDAY, JULY 01 – HOLLAND...ARRIVAL AT THE AMSTERDAM AIRPORT AND TRANSFER TO YOUR HOTEL.** Morning arrival at Amsterdam Airport. After instruments and luggage are loaded, board your motor coach to transfer through the Dutch Lowlands, much of which are below sea level. The canals, dikes, bridges and windmills seen along the way create your first impressions of The Netherlands (often referred to as Holland). A two-night stay will introduce you to Dutch "gezelligheid," a friendly, cozy feeling. After check-in, make a leisurely visit to a windmill village. Return to your hotel for dinner.



**Day 3 – SATURDAY, JULY 02 – HOLLAND...AMSTERDAM AND DELFT.** Amsterdam, Holland's colorful and lively capital city, awaits you this morning. The 17th-century canal houses with their gabled roofs are a photographer's delight and you will be amazed by the number of bicycles while you tour the city in a glass top boat. As you transfer to Delft, prepare to be captivated by the picturesque streets lined with medieval architecture, characteristic canals, friendly cafés, and inviting shops selling the famous Delft Blue earthenware. The DeWitt High School Band will perform their first concert of the tour on Delft's Market Square. After the concert, you will have time for an independent dinner, allowing you the opportunity to try Dutch pancakes before returning to your Holland hotel.

**Day 4 – SUNDAY, JULY 03 – BELGIUM/FRANCE...VISIT ANTWERP AND TRAVEL THROUGH FRANCE TO PARIS.** Traveling south, leave Holland and cross the border into Belgium. Make an early lunch stop in Antwerp to view its impressive Cathedral of Our Lady and beautiful guild houses. Take a walk through the Old Town where friendly sidewalk cafés will tempt you to order a scrumptious Belgian waffle for lunch. Candy shops will also entice you with an endless selection of irresistible chocolates. In the late afternoon you enter France and by dinner time you have reached Paris, "The City of Light." A characteristic French bistro will host dinner before you transfer to your hotel for check-in.

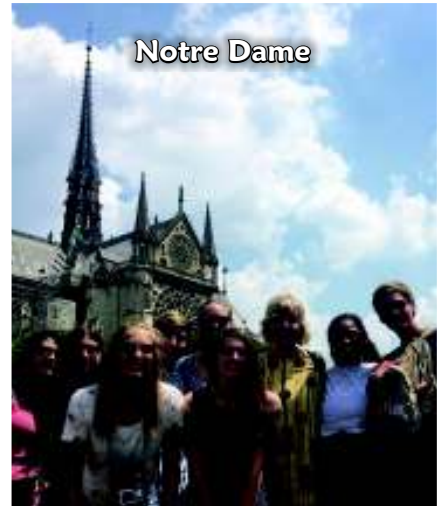

**Day 5 – MONDAY, JULY 04 – FRANCE...PARIS.** Start your exploration of Paris with a photo stop at the impressive Sacré-Cœur Basilica, in the Montmartre District. Next, a leisurely Seine River boat ride provides views of the Eiffel Tower and Notre Dame Cathedral. During the free time in Paris, students will be required to stay together in groups with the choice of exploring the area surrounding either the Notre Dame Cathedral or the Louvre Museum (in the past the museum has offered free entrance for students 18 and under). In the afternoon, travel to your hotel in Troyes, France for dinner and overnight.

**Day 6 – TUESDAY, JULY 05 – FRANCE/SWITZERLAND... BURGUNDY TO THE SWISS ALPS.** You may wish to rise early and walk into Troyes' picturesque medieval village square. This will be a full day of travel through the vineyards of the Champagne, Burgundy and Alsace regions. Make a brief lunch stop near

# 15-day DeWitt Europe Concert Tour 2022

the university town of Besançon. Cross the border into Switzerland and continue past Basel, strategically situated at the point where Switzerland, Germany and France meet. You will spend the next two nights in the majestic Swiss Alps.

**Day 7 – WEDNESDAY, JULY 06 – SWITZERLAND... MT. STANSERHORN AND LUCERNE.** The day focuses on an unforgettable excursion to the top of Mount Stanserhorn, located on the edge of gorgeous Lake Lucerne. From the village of Stans take a cogwheel train and then a cable car up the 6000-foot mountain for incredible views. Take in the panoramas from the ideally situated viewing platforms, while relaxing at the mountaintop restaurant, or during an exhilarating hike. In the afternoon, visit the lovely town of Lucerne to walk the covered bridge and shop for delicious Swiss chocolate. The DeWitt High School Band will perform in the village of Stans this evening.

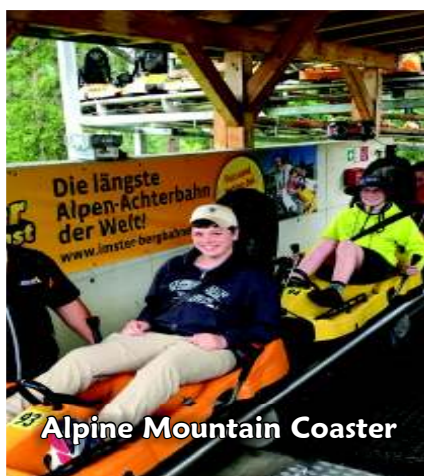

**Day 8 – THURSDAY, JULY 07 – LIECHTENSTEIN/AUSTRIA... VADUZ AND INNSBRUCK.** Travel through the Swiss Lake District and into the small country of Liechtenstein for a short visit to its capital of Vaduz. Liechtenstein is nestled between Switzerland and Austria and is a center for stamp collecting. Then, enter the Austrian Alps on the way to imperial Innsbruck, located on the River Inn to which it owes its name (Brücke = bridge). Innsbruck is the capital of Tyrol, one of Austria's nine provinces. One of the city's most iconic sights is the Golden Roof Balcony, built during the rule of Emperor Maximilian I so he could watch entertainment in the square below. In the late afternoon, the DeWitt High School Band will perform in Innsbruck. After the concert, transfer to your hotel for a two-night stay in one of the neighboring mountain villages.

**Day 9 – FRIDAY, JULY 08 – GERMANY/AUSTRIA...ALPINE COASTER AND NEUSCHWANSTEIN CASTLE.** You are in for a thrilling day, starting with an Alpine Coaster ride. Take a chair lift up to where individual toboggans equipped with manual brake controls follow a winding rail through breathtaking scenery as you coast down the

mountain. Another highlight is the visit to Neuschwanstein Castle in Germany. You will recognize this as the model for the castle at Walt Disney World. Neuschwanstein was the creation of 'Mad' King Ludwig II of Bavaria who made it a habit to build elaborate castles with the state's money. Walk up the mountain where a tour of the castle interior is included. To top of this exciting day, attend a Tyrolean Folklore Show this evening, presenting traditional dancing, yodeling, and unique musical instruments.

**Day 10 – SATURDAY, JULY 09 – AUSTRIA/GERMANY/AUSTRIA... BERCHTESGADEN SALT MINES.** The Tyrolean Alps provide stunning scenery on the way to Berchtesgaden, Germany. After a scenic lunch stop, another memorable experience follows at the Berchtesgaden Salt Mines. Donned in mine workers' garb – cap and all – descend deep into the mountain interior by way of a small train. After an explanation of how the salt is extracted, take a thrilling ride down the giant slides. Return to Austria, this time in the breathtaking province of Salzburg. Spend the next two nights among the natural beauty of mountain-fed rivers and flower-laden meadows.





# 15-day DeWitt Europe Concert Tour 2022



**Day 11 – SUNDAY, JULY 10 – GERMANY/AUSTRIA...EAGLE'S NEST AND SALZBURG.** What a way to wake up, surrounded by the splendid scenery of the Austrian Alps! Take a short ride to the Eagle's Nest, Adolf Hitler's hideaway during WWII. The views into both Germany and Austria from the 6000-foot-high Eagle's Nest are said to be the most outstanding in the Alps. You can also see Salzburg, your afternoon destination. Dominated by the imposing hilltop fortress and bisected by the Salzach River, this baroque city abounds with elegant buildings, fountains, squares and gardens. During free time here, you may enjoy strolling through Salzburg's famous shopping streets with the highly ornate, wrought iron signs on their storefronts. The DeWitt High School Band will perform an afternoon concert in the Mirabell Garden. Scenes from *The Sound of Music* were filmed on these beautifully manicured grounds.

**Day 12 – MONDAY, JULY 11 – GERMANY/AUSTRIA...VISIT DACHAU.** After breakfast, cross the border into Germany once again, and travel north by way of the Autobahn. After a short lunch stop, arrive in Dachau for a somber afternoon visit to the former concentration camp. Those who prefer may remain in the Visitors Center at the entrance. Your accommodations for tonight will be at one of the medieval walled cities along the Romantic Road.

**Day 13 – TUESDAY, JULY 12 – GERMANY ... ROTHENBURG AND RÜDESHEIM.** This morning, transfer to Rothenburg-ob-der-Tauber. As you walk into the center of this storybook village, you are sure to be enchanted by the intact city walls, cobblestone streets, historic inns, and quaint shop fronts. You may wish to climb up to the 'Rathaus' Bell Tower for a birds-eye view of the city. Perhaps one of the many bakeries will tempt you to try a local treat. Visit one of the unique museums, stroll through the peaceful Castle Gardens near the River Tauber, or browse the magical displays in the year-round Christmas shop. The DeWitt High

School Band will perform their final concert on the Rothenburg Market Square. In the afternoon, continue north to your hotel in Rüdeseim, arriving just before dinner.

**Day 14 – WEDNESDAY, JULY 13 – GERMANY... CRUISE ON THE RHINE RIVER AND RÜDESHEIM.** A Rhine River Steamer awaits to take you on a scenic boat ride past medieval fortresses, quaint villages, hillside vineyards and the legendary Lorelei Rock. Spend the rest of the day in Rüdeseim. Walk along the attractive Rhine River promenade and the pretty Drosselgasse, the main shopping street; visit the unique Siegfried's Mechanical Music Cabinet Museum; or take a cable car ride up to the Neiderwald Monument for a scenic hike with amazing views of the Rhine River Valley. Before dinner, it is time to pack up all the instruments and get ready for your return flight home tomorrow.

**Day 15 – THURSDAY, JULY 14 – GERMANY/USA...TRANSFER TO FRANKFURT AIRPORT.** Early this morning, transfer to Frankfurt Airport to check in for your flight. Return home a richer person, having gained special life-long memories.



# FAQ (Frequently Asked Questions)

Knowing as much as you can beforehand will enable you to enjoy your tour experience to the fullest. The information in the FAQ section is based on what was known at the time of printing and is subject to change at any time. The terms and conditions of your travel arrangements are controlled by the Tour Contract, and it is necessary that you read through these next three sections (FREQUENTLY ASKED QUESTIONS, PHYSICAL CONDITION GUIDELINES and TOUR CONTRACT) prior to making your reservation.

**Are Passport Books required?** Passport Books are required for all travelers. Please be sure that your passport is valid for at least 6 months after your scheduled return date. If you need to apply for, or renew, a passport, start the process as soon as possible and at least six months prior to departure.

**Are Visas or Vaccinations required?** Non-U.S. Citizens must check with their embassy or consulate, before making a deposit, to determine which vaccinations or visas they will need for each of the countries they will visit. At time of printing, no visas are required for passengers carrying a U.S. passport. Vaccination, visa and other documentation requirements are subject to change, and it is the passengers' responsibility to become familiar and fulfill the requirements applicable at time of travel. Image Tours will make every effort to pass along new information applicable to U.S. passport holders as it becomes known but is not responsible for the consequences due to the inability, for any reason, to provide proper documentation at time of travel. Cancellation or denied entry due to the inability to obtain or provide proper documentation or meet requirements will be subject to the Image Tours "Cancellations" policy.

**Are Airport Transfers included?** Complimentary airport/hotel transfers are scheduled based on the arrival and departure times of participants who purchased 'Air & Tour Inclusive' from Image Tours. Passengers who purchase 'Tour Only' from Image Tours should expect to make their own way between the airport and the hotel at their own expense, but are welcome to join the complimentary transfer if the passenger's flight times coincide with the actual group transfer times. Student bus participants are expected to purchase 'Air & Tour Inclusive' to assure travel on the same air as the rest of the group. Requests to book air separately are subject to approval by Image Tours and the group leader.

**May I request Airline Seat Assignments?** The airlines will assign seating. Image Tours does **not** accept any special requests for seating on the STUDENT tour. For the ADULT tour, seating requests received by Image Tours, in writing, more than 100 days prior to departure will be noted but will not be guaranteed.

**May I record Frequent Flyer information?** If you are a member of a frequent flyer club and if the airline offers miles for tickets issued by Image Tours, it is your responsibility to make sure that you are credited your miles. The best way to do this is to enter your information through

the airline website a week prior to departure. Image Tours recommends you record your ticket number and keep your boarding passes even after you have returned, and until your frequent flyer statement includes your miles, so you have proof of travel to show the airline if necessary. Image Tours cannot provide hard copies of tickets.

**Air Schedules** Prices are based on Economy Class fares. The airlines and air schedules provided by Image Tours are subject to change at any time, and cancellation by tour participant due to airline or schedule changes, will be subject to the cancellation penalties as outlined in the 'Cancellations' section. If tickets are purchased by a source other than Image Tours, Image Tours shall not be held liable for any penalties incurred from the cancellation or change of the air ticket, for any reason. Therefore, we recommend tickets purchased through another source not be issued until within 75 days prior to departure.

**Is it possible to Extend the Stay?** Air for the students and group leaders/chaperones must be blocked as a group traveling on the same departure and return dates in order to better assure that students will travel together with the group leaders/chaperones. All students are required to depart on the same date as the group. All requests to deviate from the return date will be subject to availability and require the approval of Image Tours and the group leader. Additional fees and/or price increases will be charged to cover additional costs/time in association with any deviation. If approved and available, the legal guardian is responsible to provide proper arrangements directly with/to the airline, such as an adult travel companion or documentation for a minor traveling alone. Deviations to the return date may be limited or may not be available. Requests must be submitted, in writing, including specific date, and will be considered in the order received. The sooner the request, the better chance of availability, acceptance, and minimizing additional cost. Regardless of availability, requests for return date deviation will not be accepted by Image Tours within six months prior to departure.

**What if I need to Return Home Early Unexpectedly?** Air tickets are subject to change fees, and you may need to purchase a non-restrictive, one-way air ticket if you need to change your return date or location. If you must return early for a medical reason, obtain a statement from the attending physician/hospital, as this documentation may help reduce airline fees and will be necessary to make a claim with the Travel Protection Plan.

## FAQ (Frequently Asked Questions)

### **Will any credit be available for Unused Tour Nights?**

There will be no credit or refund for unused services. With prior notice to Image Tours or the Tour Manager, you may leave the tour at any stop, but may only rejoin at one of the overnight hotels. Students may not leave the tour without prior approval from the group leader.

### **How are Rooms Assigned for the Student Buses?**

These will be assigned by the group leader.

### **Are Single Rooms or assistance finding a Roommate offered for the Adult Bus?**

Single Rooms for the ADULT bus are usually much smaller and not as well located as double or twin rooms, and only a limited number are available at a \$900 supplement. Although highly unlikely, if you have paid the single supplement and are forced to share a room, an appropriate refund will be made. If you are a single traveler on the ADULT bus and are a non-smoker, you may request, on your Reservation Application, for Image Tours to place you on a list of passengers looking for a roommate. Please note, if you request to be placed on the list of passengers looking for a roommate, you are authorizing Image Tours to give your contact information to prospective roommates. It will be your responsibility to contact prospective roommates. Image Tours will need to receive a written request from both roommates to remove your single supplement and assign you to a twin room. If you do end up in a single room for the entire tour or at any time during the tour, for any reason, you will be responsible for the single supplement.

**Are Triple Rooms offered for the Adult Bus?** Triple Rooms for the ADULT bus usually consist of one double or two twin beds with a folding bed or cot for the third person, and may not be comfortable for three adults. There are no discounts for triple rooms.

**Is this a Non-Smoking Tour?** The term "smoking" also refers to vaping/e-cigarettes. Student participants are not allowed to smoke at any time during the tour. For the ADULT bus, regardless of the policies within the countries or facilities visited, the tour manager will adopt a non-smoking policy on/near the motor coach, during breakfasts, during group dinners and during any other group activities. Image Tours requests non-smoking rooms for all tour participants, where possible. In fact, many hotels have converted to only non-smoking rooms and charge a substantial penalty to guests who smoke in a non-smoking room. Image Tours expressly disclaims any responsibility or liability in connection with smoking or non-smoking requirements.

**What do the Hotels serve for Breakfast?** Breakfasts are commonly served buffet style with a selection of rolls, butter, jam, cheese, cold cuts, coffee, tea, milk and juice. Breakfast usually also includes one or more other items such as cereal, sweet rolls, fruit, yogurt, eggs, or other items. Some options and preparation will reflect the local area.

**What is typical for the included Dinners?** Dinners are most commonly served at the tour accommodations following a prearranged, fixed menu. We work closely with the restaurants to provide a variety of dishes throughout the tour. Unless otherwise advised by your tour manager, beverages are not included with dinners. Although it is not customary in Europe, our hotels will provide tap water with dinner as a special courtesy to Image Tours' clients.

**May I request Special Diet Meals?** If notified, in writing, at least 100 days prior to the departure date, Image Tours accepts the following diet requests only: 1) diabetic; 2) gluten-free; 3) vegan; 4) vegetarian with dairy and eggs; 5) semi-vegetarian (no pork or red meat); 6) no shellfish/fish; and 7) lactose-free. Please specify any serious food allergies. Although we will inform the tour manager and the hotels, any dietary requirements remain entirely your own responsibility. Please do not give the tour manager a list of items you may or may not eat. New requests during the tour cannot be accommodated. Leave items you may not eat on your plate and order additional items, at your own expense. Alternatives may not be available for the students. Therefore, you may wish to pack a few 'sealed' snacks or purchase them during the day, just in case. Image Tours expressly disclaims any responsibility or liability in connection with dietary requirements.

**Will the Tour Manager accompany us throughout the entire tour?** One Tour Manager will provide coordination for all the STUDENT buses. One tour manager will accompany each ADULT bus. Under certain circumstances, Image Tours may have the driver double as tour manager on the ADULT bus.

### **Are Tips for the Tour Manager & Driver included?**

The tour price includes tips, taxes and service charges for all aspects of this tour that are prearranged by Image Tours, including tour managers, drivers, hotel staff, and restaurant staff. Any additional tipping is strictly at your own discretion and must never be considered mandatory, either by the tour participants or by the tour personnel.

**Is there a Bathroom on the Motor Coach?** Although motor coaches are equipped with an enclosed portable toilet, you are asked to limit use to 'emergencies only', due to infrequent disposal sites. Frequent sightseeing and rest stops will be made to allow for a comfortable experience.

### **Do the Motor Coaches have Heating & Air Conditioning?**

All our motor coaches are equipped with heating and air conditioning. Due to stringent pollution prevention laws, the motor coaches must turn off their engines (which also turns off the heating and air conditioning) when at a standstill (for example, while parked or waiting at a light). On warmer days when air conditioning is in use, the temperature in the motor coach is about 10° lower than outside temperature. For instance, on an 80° day the temperature on the motor coach will be about 70°.



# FAQ (Frequently Asked Questions)

## Do Hotels have Heating & Air Conditioning?

Due to a mild climate, air conditioning is not as widely used in Europe as it is in the U.S.A. Therefore, most of the accommodations do not feature air conditioning. All hotels are equipped with central heating.

**What is the Weather like?** The climate of Western Europe is comparable to that of Midwestern U.S.A.. Like most places, the weather is unpredictable. Pack for summer weather, but also bring a sweatshirt and raincoat.

## How can I use my Cell Phone during the tour?

Contact your cell phone provider about short term international data and calling plans. If you have a smartphone, WhatsApp is a cost-free way to communicate with other smartphones. If you will use your phone for photos, consider increasing your memory and taking a USB battery pack.

**What happens if I am Lost?** At each stop, write down the meeting time and the name of the cross streets or landmark near your meeting point so you can ask for assistance in case you get lost. In the unlikely event that you do not arrive at a meeting point on time, proceed to your next hotel using a taxi, train or bus. All costs will be at your own expense. If you need to do this, you can ask police, public bus, train station or tourist office personnel for direction. Always carry your passport and a copy of your Overnight Schedule with you! Student participants will be required to stay with travel buddies at all times. Students are expected to be on time for all departures and late students will be responsible for the consequences, including their costs (and the costs of the chaperone who has to stay behind) to catch up with the group.

**What happens if I Lose an Article?** Neither Image Tours nor any company contracted through Image Tours shall be responsible for articles lost, stolen, left behind, confiscated or damaged. To prevent disappointment, check to ensure that you have all your possessions each time you leave a motor coach, hotel, restaurant, shop, and on all other occasions throughout your tour. Out of consideration for your fellow travelers, do not ask the driver/tour manager to wait or turn back to retrieve a lost article. If services are able and willing to attempt to ship the item, all retrieval and shipping costs (on average \$75 per item) will be the responsibility of the owner, even when unsuccessful. Phones and other electronic devices may not be shipped internationally.

**May I leave my Carry-on in the Motor Coach?** You will not be able to store your carry-on in the luggage compartment under the motor coach. During the day, leaving your carry-on in the motor coach (you must place it under your seat) is at your own risk. You must remove your carry-on from the motor coach upon arrival at the hotel each day.

## Baggage:

1) **Suitcase – Motor Coach Allowance:** Each participant on the tour is allowed one suitcase on the motor coach. The suitcase cannot exceed 50 lbs in weight and cannot exceed 62 total linear inches (length + height + width, excluding wheels and handles – Examples: 28" x 21" x 10.5" or 29" x 21" x 11"). Participants will need to carry their own luggage throughout the tour.

2) **Suitcase - Airline Allowance:** Airline baggage fees are not included in the tour price and must be paid by the tour participant directly to the airline at time of airport check-in. As of this writing but subject to change, the suitcase allowance described in "1)" above also applies to the airlines, free of charge.

## 3) Carry-on Allowance:

a) **STUDENT BUSES** participants will need to bring instruments, equipment or supplies as their carry-on. We expect that instruments, equipment and supplies in cases measuring less than 50 linear inches will need to be taken as the carry-on. This includes Flutes, Clarinets, Oboes, Alto Saxophone, Trumpet, Bassoons, Tenor Saxophones, and Trombones. Those of you with flutes, clarinets or oboes may prefer to pack your instrument in your suitcase. Those who do not have an instrument as a carry-on will need to assist with the larger cases and equipment or may be assigned to take equipment or supplies as a carry-on. Students may bring a small tote, such as a purse, small backpack, fanny pack or small hand bag. This should not have wheels and should be made of light, flexible material that is easy to carry over your shoulder. This applies to all Student participants, regardless if they are assigned an instrument or equipment as a carry-on.

b) **ADULT BUS** participants may bring one carry-on to fit under the motor coach seat. This space measures 15" x 12" x 7". (Note: wheeled carry-ons are not suitable). Adult bus participants may also carry a small tote/purse/camera bag.

4) **Loss or Damage:** Baggage loss or damage sustained while in the custody of an airline, hotel, bus company, or transfer company is not the responsibility of Image Tours. A statement outlining airline liability for passengers' baggage, as part of the Contract of Carriage, can be found on file for inspection at the offices of the airline or on the airline website. The airline's liability shall in no event exceed the actual loss incurred by the passenger, subject to proof of amount of the loss.

Baggage Size Allowances

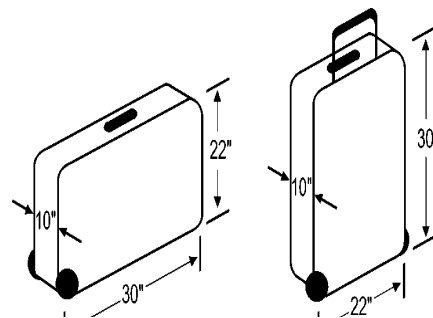

# Physical Condition Guidelines

## **Tour Pace and Walking Requirements:**

Due to limited access for motor coaches to enter town centers, a fair amount of walking, three or four miles per day regularly encountering uneven surfaces and steps, is required to take in all of the old-world charm and sights on this tour. Consequently, these tours are a good fit for persons who can comfortably walk a mile within 30 minutes without shortness of breath or other physical discomfort. If you are concerned about your physical condition, please consult your family physician as to whether the tour is suitable for you and consider the following points:

- 1) During free time and at sightseeing stops, all passengers must exit the motor coach. Staying on the motor coach during stops is not an option. When parked, all passengers must disembark so the driver can lock the motor coach and take a break.
- 2) Tour personnel, hotel staff, drivers, group leaders, and chaperones will not be available to provide repetitive, special attention to any one tour member or to lift/physically assist a tour member. If you require any type of support, you must bring a capable travel companion who can comfortably help you keep up with the pace of the tour.
- 3) The tour manager may ask a passenger to leave the tour if that passenger is unable to keep up with the pace of the tour to the extent that it impedes the safety or overall enjoyment of that passenger or other tour members. All resulting costs will be solely that passenger's responsibility.

**Wheelchairs or other Walking Devices:** Image Tours does not recommend these tours for passengers who require the use of a wheelchair, cane, walker, or other walking assistance device, or for passengers who are considering the use of a walking assistance device while on this tour. If this applies to you and you still decide to make a reservation request, please note the following:

- 1) A walker or similar walking assistance device is not practical or safe on the tour due to motor coach entrances, uneven sidewalks, and cobblestone streets. You will need to leave it home and bring a folding wheelchair. If you regularly use a cane and feel confident that you will have no difficulty sturdily and comfortably walking a mile in less than 30 minutes (including steps and cobble stone streets), Image Tours still recommends bringing a wheelchair as a back up.
- 2) You must be able to manage the steps of the motor coach independently. In Europe, the laws do not require

motor coaches to be equipped with ramps/lifts, or hotels to offer provisions for the physically challenged. Please do not expect these facilities on this tour.

- 3) You must bring your own manual, folding wheelchair. Motorized wheelchairs are **not** allowed on this tour.
- 4) You must bring a capable travel companion (Image Tours recommends traveling with two or more capable companions for the greatest success) who can confidently push the wheelchair and assist you in any way necessary to comfortably keep up with the tour pace.
- 5) At time of reservation you must obtain, complete, and return a 'Wheelchair Request' form (provided by Image Tours), signed by both you and your traveling companion(s). Requests will be subject to Image Tours' approval and availability of storage space. If the request is received after deposit and declined by Image Tours, the applicable cancellation penalties will apply.
- 6) The charge to store a wheelchair under the motor coach during the tour is USD \$10.00 multiplied by the total number of tour days. This amount is to be paid with final payment for the tour.
- 7) Make sure you and your travel companion feel confident using a wheelchair outside your home before making a reservation. Passengers who are not comfortable using a wheelchair on a daily basis before the tour tend to be less likely to successfully complete the tour. No credits or refunds will apply for missed sights, tour features or wheelchair storage fees. Additional costs to keep up with the tour or return home early will be entirely the tour participant's responsibility.

**Oxygen or other Medical Devices:** Oxygen tanks will not be permitted on the motor coach. Due to higher elevations and the tour's active pace, clients dependent on oxygen assistance devices should not take this tour. CPAP and other medical devices must fit within the "Baggage Allowances" for the tour. Under no circumstance does Image Tours, the airlines, the motor coach company, the tour manager, the hotels or any other service provider, the group leader, or any other entity associated with the tour accept any responsibility or liability in connection with medical conditions, medical devices or any electronic devices.

**Geographical Elevations:** At 3500 feet, the hotels in Austria and Switzerland are the highest expected elevation on the tour. If it is necessary to take the Arlberg Pass instead of the tunnel, the elevation is 5883 feet. Image Tours accepts no liability for inaccuracies or variations.

# Tour Contract

**General:** Upon full payment of the tour price by the participant, Image Tours, Inc., 2828 Kraft Ave. S.E., Grand Rapids, MI 49512-2076, Ph: 616/957-1010, Fax: 616/957-0103, hereinafter referred to as "Image Tours," agrees to provide the services specified in this brochure, subject to the terms, conditions, and limitations contained in this contract. The participant agrees that if there are any corrections or changes, the correct information will prevail.

**Included:** Please consult the "Included Features" page and the itinerary.

**Not Included:** All costs not included in "Included Features" for example, fees and charges for beverages (except coffee/tea/milk/water with breakfast or when expressly specified), passports, visas, inoculations, medical exams/tests, laundry, postage, phone calls, any items of a personal nature, or any other items/services the inclusion of which has not been expressly specified. Also not included are any fees associated with (or in connection with) air transportation, including but not limited to seat assignments, airports & baggage. Luggage service is NOT provided and participants are responsible for carrying their luggage throughout the duration of the tour.

**Airlines, Tour Managers, Drivers, Accommodations:** Image Tours strives to coordinate a pleasurable and memorable trip for all of its customers, but it must be remembered that all aspects of the tour, including but not limited to travel, accommodations and services, are furnished by independent companies which are not under the direct control of Image Tours.

**Itinerary Deviations:** Due to special circumstances (including but not limited to holidays, special events, seasonal schedule changes, weather,

safety considerations, government restrictions, traffic delays and itinerary adjustments), some sights and stores may have reduced hours or may not be available. Under such circumstances or toward the improvement of the tour experience, Image Tours and the tour manager reserve the right to make changes in the itinerary or sights, at their sole discretion.

**Participants 17 and under:** For participants ages 17 and under a legal guardian must sign their Reservation Application and a Consent Form. The Consent Form will be provided by either Image Tours or the group leader prior to final payment. A \$300 discount off the Adult bus "Tour & Air Inclusive" price will apply for children who will be 9 to 11 years of age at time of travel and are sharing a room with at least one legal guardian. No discount applies to the Tour Only price. Children under 8 years of age are not accepted on the Adult bus, as it is difficult to keep them entertained on the motor coach.

**Payment Schedule:** Payments are due as follows:

May 12, 2021: \$100 per person accompanied by the signed Reservation Application.

October 20, 2021: \$499 per person Includes the \$249 non-refundable Travel Protection Plan.

January 19, 2022: \$1500 per person

March 16, 2022: Balance Due

Note: Those who prefer, may choose to pay \$1000 per month or \$500 every two weeks starting in December, as long as they still meet the deadlines stated above and the form of payment remains the same for all payments after the \$499.00 deposit (all by check/ACH or all with the same credit card number).

If all required payments after the \$499 deposit are by check or ACH, and received before each deadline, you may subtract a \$100 discount off your final payment.

Make checks payable to Image Tours.

If paying by credit card (we accept DISCOVER®, MASTERCARD® and VISA®) you will need to provide your signature for authorization on an invoice.

Send payments to: Image Tours, 2828 Kraft Ave SE, Grand Rapids, MI 49512.

Image Tours reserves the right to cancel a reservation for which it has not received payment by the due date, or when a check is returned due to insufficient funds; and all cancellation penalties will apply.

**Change Fees:** After Image Tours processes the deposit, all change requests must be submitted in writing and are subject to availability and acceptance by Image Tours. **Tour changes** (to a different tour date or itinerary), or **name changes** (substitutions) are always considered cancellations/new reservations and are subject to the image Tours "Cancellations" policy. If confirmed by Image Tours, changes such as departure/return date (when the tour date remains the same), departure/return city in U.S., arrival/return city in Europe, "Tour & Air Inclusive" to "Tour Only" and vice versa, and spelling of participant's name will be subject to the following change fees, in addition to any increase in participant's price:

- 1) Prior to final payment, \$100 per person.
- 2) After final payment, all changes are considered a cancellation and new reservation and are subject to the Image Tours "Cancellations" policy.



# Tour Contract

**Cancellations:** Image Tours must receive a written notification of cancellation. Using the date such notification is received, the following cancellation penalties apply and will be retained by Image Tours:

- 1) Prior to October 20, 2021: \$100 per person withheld.
- 2) October 21, 2021 to January 19, 2022: \$599 per person withheld.
- 3) January 20, 2022 to March 16, 2022: \$799 per person withheld.
- 4) March 17, 2022 until the day before departure:
  - a) With a medical statement as defined below, \$799 per person plus any costs related to air (maximum \$1999 total) withheld.
  - b) Without a medical statement, \$1749 per person plus any costs related to air (maximum \$2949 total) withheld.
- 5) Scheduled departure date and after, no refund.

**Notes:** Those cancelling for a covered reason may make a claim for all amounts withheld by Image Tours except the \$249 per person Travel Protection Plan payment. No refund will be issued for any unused portions of the tour. No refund will be processed until Image Tours receives proper documentation and, if applicable, a refund from the airlines.

**Medical Statement:** To be eligible for the refund provision under section **4)a** of "Cancellations," it is your responsibility to make certain Image Tours receives a medical statement, deemed acceptable to Image Tours, within six weeks of the date you were scheduled to depart. Otherwise, your cancellation will be processed in accordance with section **4) b** of "Cancellations." A valid medical statement must meet all the following:

- 1) A legible medical statement on the letterhead (including the address and phone number) of an attending physician M.D., or a copy of the completed Attending Physician Statement required by the Travel Protection Plan.
- 2) Signed by the physician.
- 3) State specific dates the passenger is unable to travel. These dates must include the entire duration of the scheduled travel dates.
- 4) State a specific medical reason why the passenger was unable to travel, due to the illness of the participant. In case of death of the participant or a member of the participant's immediate family, namely spouse, child, brother, sister, parent, in-law, grandparent or grandchild, a copy of the death certificate is required.

**Policy if the group decides to postpone trip to 2023:** If, prior to October 20, 2021, the group decides to postpone the trip, participants may cancel with a full refund or transfer to the 2023 departure. If decided between October 21, 2021 and March 16, 2022, the "Cancellations" policy applies but the amount can be transferred on a per person basis (no name changes) to the 2023 departure at the original pricing. In this case, 2022 graduates would travel with the Adult Bus at the student price (in shared rooms). A group decision must be made prior to March 17, 2022 because after that date airline policies will apply.

**Price Changes:** Tour prices are based on tariffs, taxes and rates of exchange as they were known to Image Tours on the date of booking, and are subject to change, without prior notice. However, if the tour price increases by more than 5%, the participant(s) may, within seven (7) days from the date of notification of such increase, cancel with full refund.

## Responsibility of the Airlines:

The airlines are not held responsible for any acts, omissions, or events during the time the passengers are not on board their aircraft or conveyances. The passenger's contract in use by the airlines, when issued (for view on the airline's website), shall constitute the sole contract between the airline and the passenger. Any and/or all transportation companies shall have or incur no responsibility for liability to any traveler aside from their liability as common carriers. Services performed and tickets issued by the air carrier are subject to rules and regulations relating to liabilities established by the Warsaw and Montreal Conventions and the terms and conditions of the airline contract.

**Hazardous Materials Notice:** Federal law forbids the carriage of hazardous materials aboard an aircraft in your luggage or on your person. A violation can result in five years' imprisonment and penalties of \$250,000 or more (49 U.S.C. 5124). Hazardous materials include explosives, compressed gasses, flammable liquids and solids, oxidizers, poisons, corrosives and radioactive materials. Examples: paints, lighter fluid, fireworks, tear gases, oxygen bottles and radiopharmaceuticals. There are special exceptions for small quantities (up to 70 ounces total) of medical and toilet articles carried in your luggage and certain smoking materials carried on your person. For further information, review the prohibited items webpage on the TSA website: [www.tsa.gov](http://www.tsa.gov).

## Cancellation by Image Tours:

Image Tours reserves the right to cancel a tour at any time for any reason. If Image Tours is responsible for the cancellation of the tour, its liability shall be limited to a refund in full of only those moneys it has received from or on behalf of the participant. Cancellations beyond the control/responsibility of Image

## Tour Contract

Tours (including but not limited to cancellation of a group due to insufficient group participation or for any reason and factors listed in the "Responsibility" paragraph) will be subject to Image Tours "Cancellations" policy. If the air ticket is purchased through any source other than Image Tours, it is the purchaser's responsibility to become familiar with the penalties and restrictions. In the event of a cancellation or date change, Image Tours shall not be held liable for any penalties incurred from the cancellation or change of the air ticket. Therefore, we recommend tickets not be issued until 75 days or less prior to departure.

**Responsibility:** Image Tours, Inc., its employees, shareholders, subsidiaries, affiliates, officers and directors (collectively "Image Tours") does not own or operate any entity which is to provide or does provide goods or services for your trip, including, for example, lodging facilities, transportation companies, local ground handlers, tour operators, food service or entertainment providers, etc. As a result, Image Tours is not liable for any negligent or willful act or failure to act of any such person, or of any other third party not under its control. Without limiting the foregoing, Image Tours accepts no responsibility for any risk or resulting injury, delay, postponement, cancellation, inconvenience, damage, or death which results from criminal activity, accidents, disease, epidemics or the threat thereof, pandemic or threat thereof, illness, the provision of inappropriate or no medical attention or the lack of access to

same, the demands of indoor or outdoor activities, service policies, government regulations, strikes, political or civil unrest, overbooking, structural or other defective conditions in hotels or other lodging facilities, acts of terrorism or the threat thereof, insurrection or revolt, weather, acts of God or any other events or circumstances beyond its control. In addition, Image Tours is not responsible for typographical or substantive errors in descriptions.

**Travel Advisories and Warnings and Health Alerts:** It is the responsibility of the traveler to become informed about current travel advisories and warnings. Refer to the U. S. State Department's travel website at [www.travel.state.gov](http://www.travel.state.gov) or call 1-888-407-4747. For health alerts, refer to the Centers for Disease Control website at [www.cdc.gov](http://www.cdc.gov) or call 1-800-232-4636.

**Traveler's Representation:** The traveler represents that neither he nor she nor anyone traveling with him or her has any physical or other condition or disability that could create a hazard to himself or herself or other members of the tour. Image Tours reserves the right to decline to accept or retain any person as a member of the tour at any time prior to departure, or in the course of the tour, should such participant's health, mental condition, physical infirmity or general deportment impede, in Image Tours' judgment, the operation of the tour or the rights, welfare or enjoyment of other tour participants, and all resulting costs will be the responsibility of the participant.

**Entire Agreement:** Participant warrants that no promises or inducements have been offered for this agreement other than as set forth herein and that this agreement is executed without reliance upon any other promises or representations. No modification, termination or attempted waiver of this Tour Contract shall be valid unless in writing and signed by the participant and an officer of Image Tours.

**Arbitration Agreement:** Any controversy or claim arising out of or relating to this Tour Contract, to the brochure or to any information relating in any way to the trip, or to the tour itself, shall be settled solely and exclusively by binding arbitration in Grand Rapids, Michigan in accordance with the then existent commercial rules of the American Arbitration Association. In any such arbitration, the substantive (but not procedural) law of Michigan shall apply. The arbitrator and not any federal, state, or local court or agency shall have exclusive authority to resolve any dispute relating to the interpretation, applicability, enforceability, conscionability or formation of this contract, including but not limited to any claim that all or any part of this contract is void or voidable.

**Payment to Image Tours, Inc., or toward an Image Tours, Inc. tour, constitutes your acceptance of the Tour Contract as set out here.**

RESPONSIBILITY/LIABILITY disclaimers as provided to Image Tours, Inc. by the Tour Contract are hereby extended to Mr. Mike Norman, the Band Boosters, chaperones, DeWitt High School, and The DeWitt Board of Education.

# Travel Protection Plan



Image Tours' Travel Protection Plan may protect your travel investments, your belongings and you. Plan cost is non-refundable after the free look period; also, once paid, coverage is nontransferable. The Plan's exclusion for pre-existing conditions will be waived if your plan payment is received within seven (7) days of the date that your initial payment or deposit for your trip is received, provided you are not disabled from travel at the time your plan payment is paid.

## The Travel Insurance Benefits provided by United States Fire Insurance Company

Insurance Benefits	Maximum Benefit Amount
Trip Cancellation .....	Trip Cost
Trip Interruption .....	150% of Trip Cost
Missed Connection .....	\$1,000
Travel Delay (Up to \$200 Per Day) .....	\$1,000
Emergency Evacuation Accident & Sickness Medical Expense .....	\$50,000
Emergency Medical Evacuation, Medical Repatriation & Return of Remains .....	\$100,000
Non-Medical Emergency Evacuation .....	\$25,000
Accidental Death & Dismemberment	
24-Hour Other Than Air Flight.....	\$25,000
Air Flight Only .....	\$50,000
Baggage and Personal Effects .....	\$2,500
Baggage Delay (12 Hours or More) .....	\$500

**NON-INSURANCE ASSISTANCE SERVICES INCLUDED IN THE PLAN:** Generali Global Assistance & Global Xpi Medical Records Services

**INFORMATION YOU NEED TO KNOW:** Benefits on this page are described on a general basis only. **There are certain restrictions, exclusions and limitations that apply to all insurance coverages, including an exclusion for preexisting conditions.** This advertisement does not constitute or form any part of the Plan Description or any other contract of any kind. Plan benefits, limits and provisions may vary by state/ jurisdiction or may not be available in all states/ jurisdictions. Plan Payments are for the full travel protection plan, which consists of Insurance Benefits and Non-Insurance Assistance Services. The Non-Insurance Travel Deferral Option is not available for groups. Individuals looking to obtain additional information regarding the features and pricing of each travel plan component, please contact Trip Mate at 1-833-297-2255. Consumers in California may contact California Department of Insurance Hotline at 1-800-927-4357. Consumers in Maryland may contact Maryland Insurance Administration at 1-800-492-6116 or 410-468-2340.

**EXCESS INSURANCE:** The insurance provided by the this Plan shall be in excess of all other valid and collectible insurance or indemnity. To review full plan details online go to: [www.tripmate.com/wpF432i](http://www.tripmate.com/wpF432i) (Adult) / [www.tripmate.com/wpF430s](http://www.tripmate.com/wpF430s) (Student). **Insurance Benefits are underwritten by:** United States Fire Insurance Company, 5 Christopher Way, 2nd Flr, Eatontown, NJ 07724 under Policy Form Series T210 et al. and TP-401 et al. **Non-Insurance Assistance Services:** are not insurance benefits underwritten by United States Fire Insurance Company. The 24-Hour Assistance Services of Generali Global Assistance and Global Xpi Medical Records Services are provided by Trip Mate. **Travel Retailer Disclaimer:** Image Tours is not an insurer and does not have any liability for any coverage amounts. As a travel retailer, Image Tours is not qualified or authorized to answer technical questions about the benefits, exclusions or conditions of any of the insurance coverages in the plan or to evaluate the adequacy of your existing insurance coverage. Image Tours and its employees may offer and disseminate travel insurance under the direction of Trip Mate. You may have coverage from other sources that provides you with similar benefits but may be subject to different restrictions depending upon your other coverages. You may wish to compare the terms of this plan with your existing life, health, home, and automobile insurance policies. Purchasing a travel protection plan is not required in order to purchase any other products or services offered by Image Tours (CA CST#2054949-40). **For inquiries regarding the Plan:** Trip Mate, Inc. (in CA & UT, dba Trip Mate Insurance Agency) 9225 Ward Parkway, Suite 200, Kansas City, MO 64114, **1-833-297-2255 – Trip Mate Toll Free #.** [www.tripmate.com/wpF432i](http://www.tripmate.com/wpF432i) (Adult Bus) **Refer to Plan #F432i,** [www.tripmate.com/wpF430s](http://www.tripmate.com/wpF430s) (Student) **Refer to Plan # F430s.**

The information on this page is based on what was known and current at the time of printing in January 2021 and is subject to change at any time. For the most current information, refer to [www.ImageTours.com/TravelProtectionPlan](http://www.ImageTours.com/TravelProtectionPlan).



# RESERVATION APPLICATION – STUDENT & ADULT TOURS

## DEWITT HIGH SCHOOL 2022 EUROPE CONCERT TOUR

- A. To request space, each person traveling must complete and sign his/her own Reservation Application.  
(A duplicate form is provided on the reverse and you may also make copies of this form for additional passengers).
- B. Send the completed/signed Reservation Application and \$100 per person, by May 12, 2021, to:  
**IMAGE TOURS INC (DHS), 2828 KRAFT AVE SE, GRAND RAPIDS MI 49512 or dhs@image tours.com**
- C. Type or print the information requested on this application. (Put a check mark in the boxes that apply to you)
- D. To make sure you receive your documents, the address required is your mailing address. Please notify Image Tours if your address should change between the time of booking and the departure date.
- E. List your name **exactly** as it appears or will be requested to appear on your **passport**.
- F. Yes, we do need a middle name or initial (exactly as stated on passport) and “Date of Birth” for each participant.

STUDENT TOUR /ADULT TOUR       FEMALE /MALE       LAND ONLY /LAND & AIR

NAME OF TRAVELER: \_\_\_\_\_ / \_\_\_\_\_ / \_\_\_\_\_ / \_\_\_\_\_  
(Title) (First Name) (Middle) (Last Name)

ADDRESS: \_\_\_\_\_ / \_\_\_\_\_ / \_\_\_\_\_ / \_\_\_\_\_  
(No. & Street) (City) (State) (Zip)

PH: \_\_\_\_\_ / \_\_\_\_\_ / \_\_\_\_\_      EMAIL: \_\_\_\_\_  
(AC) (Home) (Alternate)

DATE OF BIRTH: \_\_\_\_/\_\_\_\_/\_\_\_\_      PLACE OF BIRTH: \_\_\_\_\_      CITIZENSHIP: \_\_\_\_\_  
(Mth) (Day) (Yr) (State and/or Country) (Country)

DIET REQUEST (see “May I request Special Diet Meals?” in the FAQ Section): \_\_\_\_\_

ONLY FILL OUT THE INFORMATION WITHIN THIS BOX IF YOU ARE ON THE ADULT TOUR

NAME OF ROOMMATE: \_\_\_\_\_

NAME OF TRAVELING COMPANION(S): (If applicable) \_\_\_\_\_

SINGLE TRAVELERS ONLY (\$900 single room supplement): If you do not wish to have a roommate, check this box .  
 If you are a non-smoker and would like to be on the list of passengers looking for a roommate, please check this box   
 Please note that if you check the box to be put on the roommate list, you are providing Image Tours permission to give out your phone number and email address to prospective roommates. We do not guarantee roommates for this tour (see “Are Single Rooms or assistance finding a Roommate offered for the Adult Tour?” paragraph in the “FAQ”).

Enclosed is my check for \$\_\_\_\_\_ made payable to IMAGE TOURS INC.

Please charge \$\_\_\_\_\_ to my Discover/Visa/Mastercard Account #: \_\_\_\_\_ CVC: \_\_\_\_\_

Exp. Date: \_\_\_\_\_ Billing Address if different than above: \_\_\_\_\_

Name of Card Holder: \_\_\_\_\_ Card Holder Signature: \_\_\_\_\_

Please charge \$\_\_\_\_\_ as an ACH from my Bank Checking Account #: \_\_\_\_\_ Routing #: \_\_\_\_\_

Name on Account: \_\_\_\_\_ Name/Address of Bank: \_\_\_\_\_

Name of Authorized Signer: \_\_\_\_\_ Authorized Signature: \_\_\_\_\_

**I have read the brochure pertaining to this tour, including “Answers to Frequently Asked Questions” and the “Tour Contract”, and I understand and accept its contents.**

SIGNATURE OF PERSON TRAVELING: \_\_\_\_\_

Sign full name as it appears/will appear in your passport. If person traveling is under the age of 18, legal guardian must also sign:

SIGNATURE OF LEGAL GUARDIAN: \_\_\_\_\_

PRINT NAME: \_\_\_\_\_ PH: \_\_\_\_\_ EMAIL: \_\_\_\_\_

**IMAGE TOURS, INC (DHS), 2828 KRAFT AVE SE, GRAND RAPIDS MI 49512**  
**Ph: 1-800-968-9161 x2290      Fax: 616-957-2610      Email: dhs@image tours.com**

# RESERVATION APPLICATION – STUDENT & ADULT TOURS

## DEWITT HIGH SCHOOL 2022 EUROPE CONCERT TOUR

- A. To request space, each person traveling must complete and sign his/her own Reservation Application. (A duplicate form is provided on the reverse and you may also make copies of this form for additional passengers).
- B. Send the completed/signed Reservation Application and \$100 per person, by May 12, 2021, to:  
**IMAGE TOURS INC (DHS), 2828 KRAFT AVE SE, GRAND RAPIDS MI 49512 or [dhs@imagetours.com](mailto:dhs@imagetours.com)**
- C. Type or print the information requested on this application. (Put a check mark in the boxes that apply to you)
- D. To make sure you receive your documents, the address required is your mailing address. Please notify Image Tours if your address should change between the time of booking and the departure date.
- E. List your name **exactly** as it appears or will be requested to appear on your **passport**.
- F. Yes, we do need a middle name or initial (exactly as stated on passport) and “Date of Birth” for each participant.

STUDENT TOUR /ADULT TOUR  FEMALE /MALE  LAND ONLY /LAND & AIR

NAME OF TRAVELER: \_\_\_\_\_ / \_\_\_\_\_ / \_\_\_\_\_  
(Title) (First Name) (Middle) (Last Name)

ADDRESS: \_\_\_\_\_ / \_\_\_\_\_ / \_\_\_\_\_  
(No. & Street) (City) (State) (Zip)

PH: \_\_\_\_\_ / \_\_\_\_\_ / \_\_\_\_\_ EMAIL: \_\_\_\_\_  
(AC) (Home) (Alternate)

DATE OF BIRTH: \_\_\_\_/\_\_\_\_/\_\_\_\_ PLACE OF BIRTH: \_\_\_\_\_ CITIZENSHIP: \_\_\_\_\_  
(Mth) (Day) (Yr) (State and/or Country) (Country)

DIET REQUEST (see “May I request Special Diet Meals?” in the FAQ Section): \_\_\_\_\_

**ONLY FILL OUT THE INFORMATION WITHIN THIS BOX IF YOU ARE ON THE ADULT TOUR**

NAME OF ROOMMATE: \_\_\_\_\_

NAME OF TRAVELING COMPANION(S): (If applicable) \_\_\_\_\_

SINGLE TRAVELERS ONLY (\$900 single room supplement): If you do not wish to have a roommate, check this box .  
 If you are a non-smoker and would like to be on the list of passengers looking for a roommate, please check this box   
 Please note that if you check the box to be put on the roommate list, you are providing Image Tours permission to give out your phone number and email address to prospective roommates. We do not guarantee roommates for this tour (see “Are Single Rooms or assistance finding a Roommate offered for the Adult Tour?” paragraph in the “FAQ”).

Enclosed is my check for \$ \_\_\_\_\_ made payable to IMAGE TOURS INC.

Please charge \$ \_\_\_\_\_ to my Discover/Visa/Mastercard Account #: \_\_\_\_\_ CVC: \_\_\_\_\_

Exp. Date: \_\_\_\_\_ Billing Address if different than above: \_\_\_\_\_

Name of Card Holder: \_\_\_\_\_ Card Holder Signature: \_\_\_\_\_

Please charge \$ \_\_\_\_\_ as an ACH from my Bank Checking Account #: \_\_\_\_\_ Routing #: \_\_\_\_\_

Name on Account: \_\_\_\_\_ Name/Address of Bank: \_\_\_\_\_

Name of Authorized Signer: \_\_\_\_\_ Authorized Signature: \_\_\_\_\_

**I have read the brochure pertaining to this tour, including “Answers to Frequently Asked Questions” and the “Tour Contract”, and I understand and accept its contents.**

SIGNATURE OF PERSON TRAVELING: \_\_\_\_\_  
 Sign full name as it appears/will appear in your passport. If person traveling is under the age of 18, legal guardian must also sign:

SIGNATURE OF LEGAL GUARDIAN: \_\_\_\_\_

PRINT NAME: \_\_\_\_\_ PH: \_\_\_\_\_ EMAIL: \_\_\_\_\_

**IMAGE TOURS, INC (DHS), 2828 KRAFT AVE SE, GRAND RAPIDS MI 49512**  
**Ph: 1-800-968-9161 x2290 Fax: 616-957-2610 Email: [dhs@imagetours.com](mailto:dhs@imagetours.com)**